

# HANDPROTEKTOR

Hand guard | Protectores de manos | Protège-mains | Paramani

Art.-Nr: 90385-00X

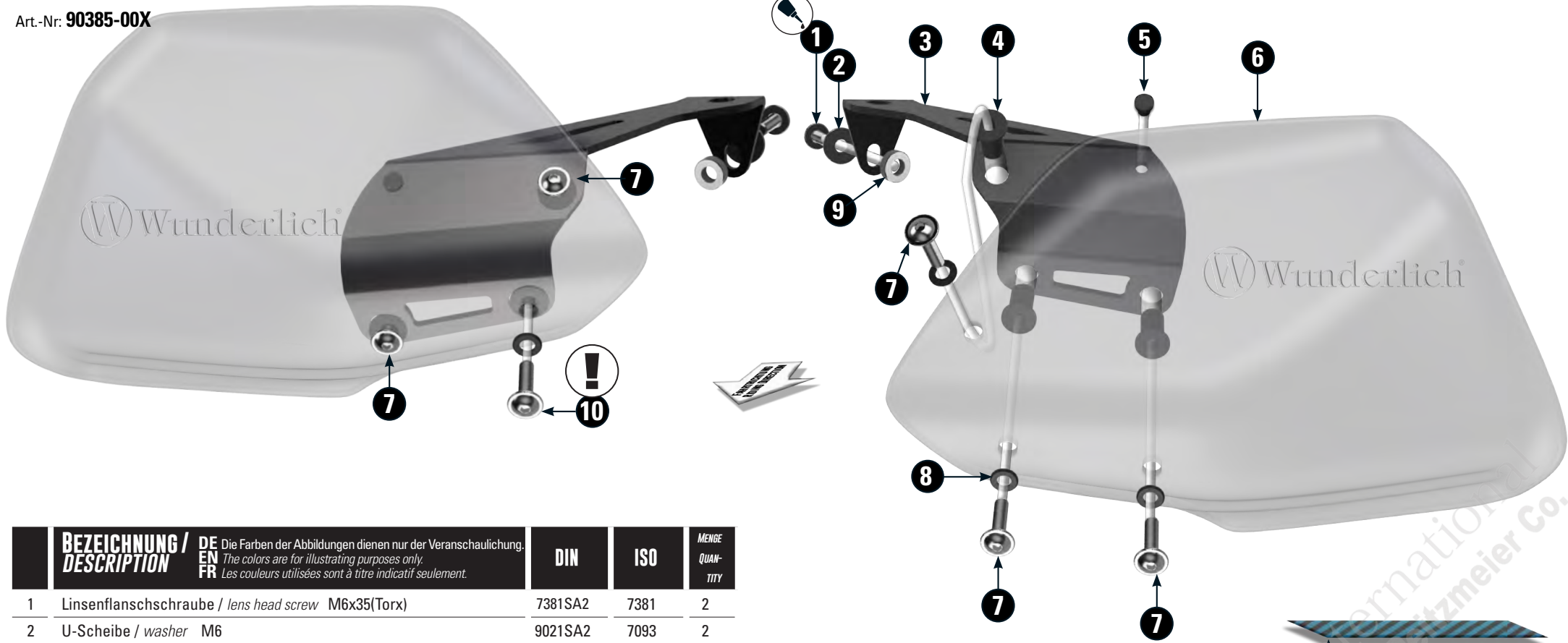

BEZEICHNUNG / DESCRIPTION	DE EN FR	Die Farben der Abbildungen dienen nur der Veranschaulichung. The colors are for illustrating purposes only. Les couleurs utilisées sont à titre indicatif seulement.	DIN	ISO	MENGE QUAN- TITY
1	Linsenflanschschraube / lens head screw	M6x35(Torx)	7381SA2	7381	2
2	U-Scheibe / washer	M6	9021SA2	7093	2
3	Halter links/rechts / Right and left bracket				2
4	Einsteckmutter / Speed nut				6
5	Gummistopfen / Rubber stoper				2
6	Handprotektor link/rechts / Right and left hand guard				2
7	Linsenflanschschraube / lens head screw	M5x20(Torx)	7381SA2	7381SA2	5
8	U-Scheibe KST / Washer plastic	M5	125KST	7089	6
9	Hülse / sleeve	ØD 12,0 - Ød 6,5 - h 4,0mm			2
10	Linsenflanschschraube / Lens head screw	M5x16(Torx)	7381SA2	7381SA2	1
11	Gummi selbstkleben / Self-adhesive rubber				2
12	Schraubensicherung / Thread locking fluid				1

## LEGENDE/KEY/FILE LÉGENDE

**Anbau Tipp**  
Fitting tip  
Astuce de montage

**Achtung**  
Attention  
Attention

**Vergrößerung**  
Magnification  
Grossissement

**Montagepaste**  
Fitting lubricant  
Lubrifiant de montage

**Zusammenbau**  
Assembly  
Montage

**Schraubensicherung**  
Thread locking fluid  
Freinfillets

**Drehmoment**  
Torque  
Torque

**Reiniger**  
Cleaner  
Nettoyant

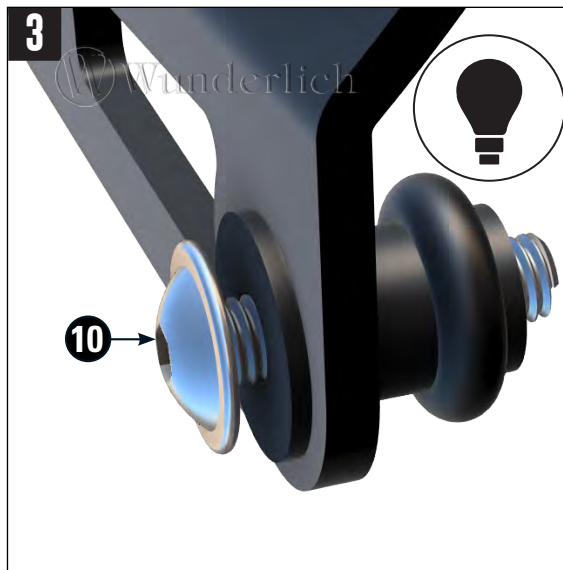
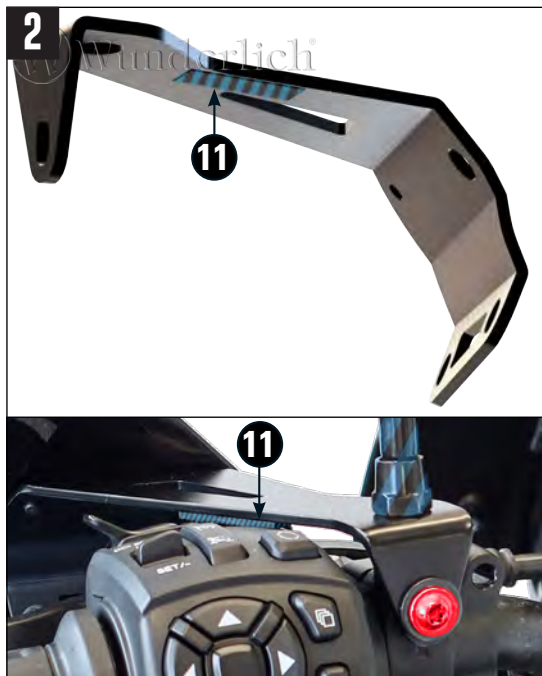

**Einsteckmutter 1x ohne Protetkor anziehen.**  
*Tighten the speed nut 1x without protector.*  
*Serrer l'écrou de vitesse 1x sans protecteur.*



**Handprotektoren vormontieren.**  
*Preassemble hand protectors.*  
*Pré-assembler les protections des mains.*

5



### Markierte Schraube lösen.

Loosen the marked screw.  
Desserrez la vis marquée.

6

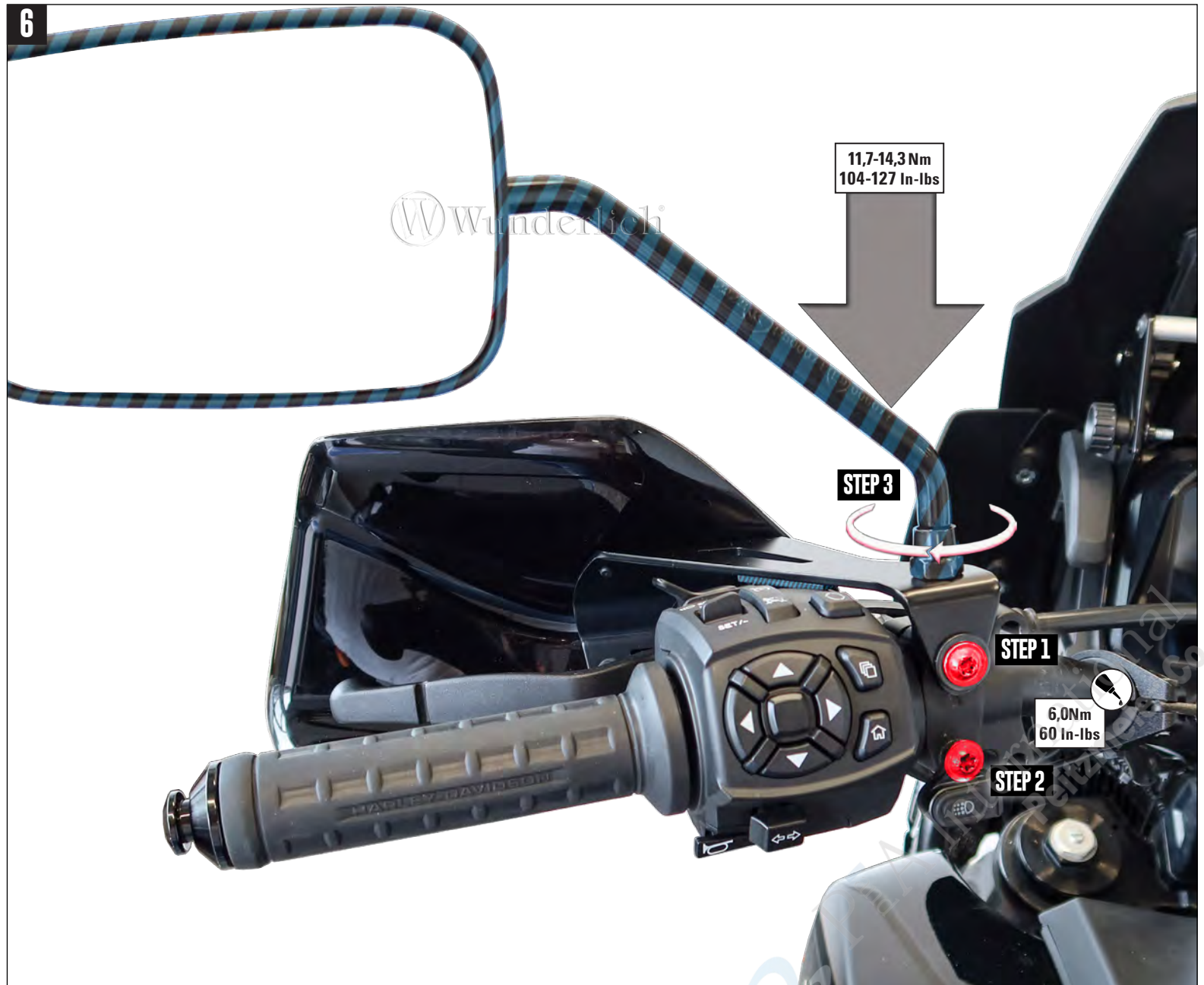

### Handprotector und Armaturen so ausrichten, dass diese nicht anstoßen.

Align the hand protector and switch fittings so that they do not bump against each other.

Alignez le protecteur de la main et les raccords de l'interrupteur de manière à ce qu'ils ne se heurtent pas l'un à l'autre.